

Polyurethane Lining Kits

for Central Mix Drums



ARGONICS
ENGINEERED POLYURETHANE

POLYURETHANE LINING KIT INSTALLATION GUIDE

INDEX

Index and Foreword	1
Exploded View and Example Parts List	2
Welding, Cutting and Drilling Techniques	3
Required Materials (Installation)	4
Installation Procedure	5
Required Materials (Removal) & Removal Procedure.	7
Proper Care and Maintenance	8
Notes	10

FOREWORD

Thank you for purchasing an Argonics Kryptane® liner!

Argonics polyurethane lining material is designed to extend the wear life and reduce the maintenance requirements of your process equipment. Years of field research, performance testing and product evaluation has led numerous Original Equipment Manufacturers to offer this lining material as the best product value available on the market today.

This manual contains important information regarding polyurethane material. Please read this entire manual before installing a liner kit. This manual includes hazards that might exist and precautions to be taken during the installation or removal of these lining systems. For more information, or for copies of MSDS information, please contact Argonics.

Argonics is proud to offer these innovative lining systems. With proper care, these liners will provide valuable service for years to come.



EXPLODED VIEW

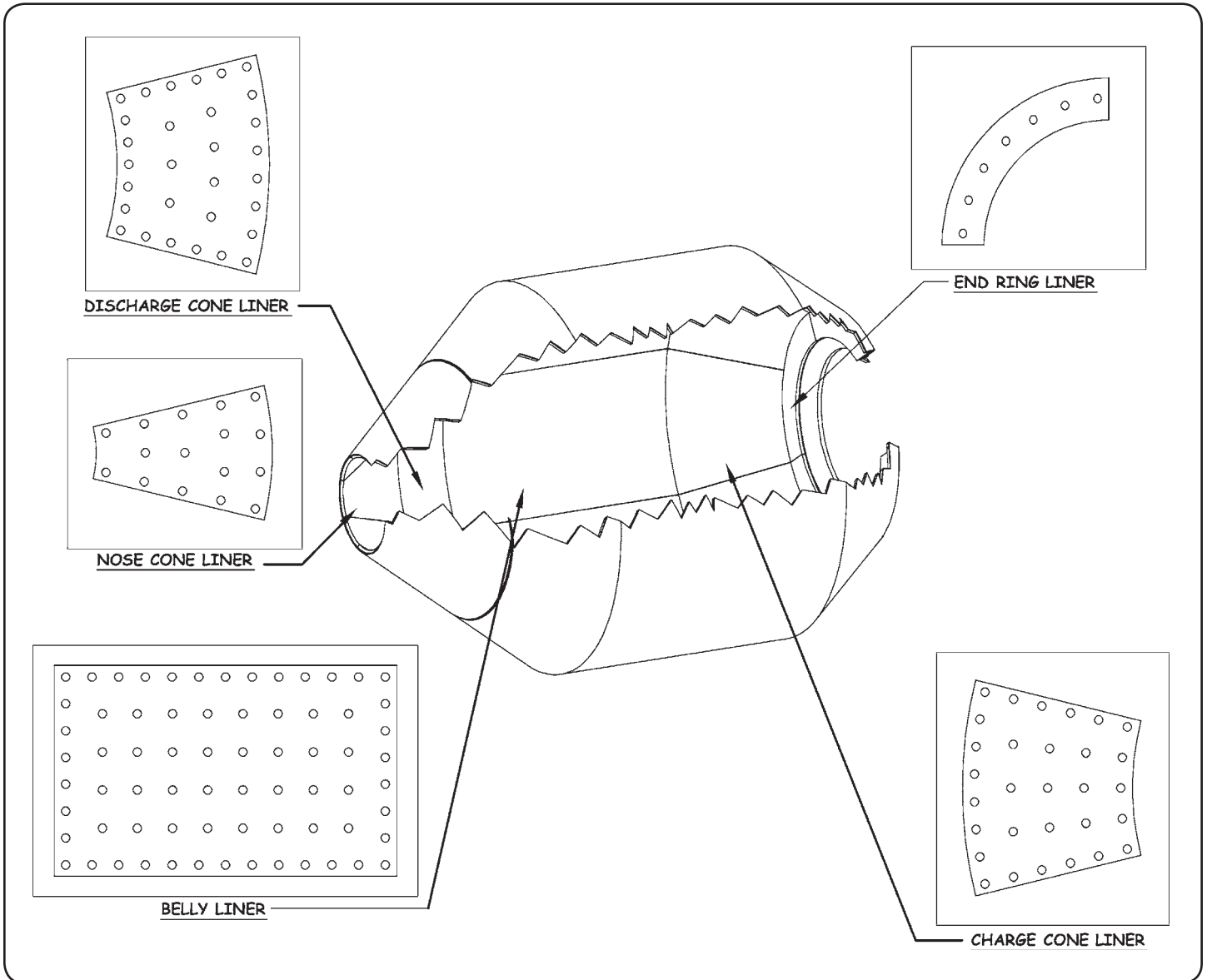

Varies based on which model of drum you may own (RexCon, Erie Strayer, McNeilus®, etc.).

Example Assembly Parts List

- 8 Belly Liners
- 8 Nose Cone Liners
- 8 Charge Cone Liners
- 8 Discharge Cone Liners
- 4 End Ring Liners

1 Case of Bostik® 1100FS
All Necessary Plugs

⚠ **WARNING** ⚠

Beware: Burning elastomers give off toxic fumes. Take extra time to minimize heat exposure. Have a fire extinguisher and a bucket of water with rags available. If flames or smolders do occur, extinguish immediately. Use of forced air ventilation or an in-line respirator is strongly recommended.

Welding, Cutting and Drilling Techniques

Position the liner as required. Apply pressure to the liner to ensure the weld disk is flush with the substrate. Drop a pipe segment (1.75" O.D. x 2" long) inside of the plug-hole opening. Hold in place with pliers or vice grips. Place welder inside of the pipe segment and plug weld around the disk hole. The pipe segment will act as a heat shield and will protect the liner from heat degradation and ignition. The pipe segments will build heat, so it is advisable to utilize multiple pipe segments. If flashes of hot slag hit the liner, use a wet rag to extinguish the smolder.

If necessary, the liners can be cut using an open tooth band saw or heavy-duty reciprocating saw. Use a course tooth blade when cutting polyurethane only, and switch to a fine tooth blade if a steel weld plate is encountered. When cutting, advance the blade slowly and run at low RPM in order to minimize friction and heat buildup. Spray water or other cutting lubricant on the area to make sawing easier. **Do not use a circular saw to cut these liners.**

Drilling is best done using a 1/2" high torque drill. The bit should be a fluted style (standard bit), and low RPM should be used. Allow time between bore holes for the bit to cool if required. Spraying the hole with water will also improve boring. Be sure to clean away shavings before welding or gluing.

ATTENTION:

Argonics specifies an industrial, high-quality urethane-based adhesive for seam sealing. We recommend Bostik 1100FS and it can be purchased from Argonics. Suitable replacements can be used, however they should be approved by Argonics. Using an unsuitable caulk or sealant will void the warranty.

Information about Bostik 1100FS

Bostik 1100 Fast Set is a one part urethane sealant that cures by reaction with atmospheric moisture to form a tough, flexible seal. It has tenacious adhesion to woods, metals, FRP and most plastics. Bostik 1100FS can be used in bonding, beading and sealing applications.

Clean Up

Uncured Bostik 1100FS may be easily removed from hands and tools with Bostik Hand & Tool Towels. Excess sealant should be dry-wiped from all surfaces and tools while still uncured. Cured sealant can be removed with a sharp blade. NOTE: Cured sealant is usually very difficult to remove without altering or damaging the surface to which the sealant was applied.

Shelf Life

When stored at or below 80°F (27°C), Bostik 1100FS polyurethane sealant has a shelf life of nine months from date of manufacture.

Typical Uncured Properties*

Property	Value
Tool/Work Life	70 minutes
Tack Free Time	90 minutes
Curing Time @ 77°F	1.5 - 3 days
Flow, Sag or Slump	Nil
Staining	None

**Typical Cured Properties*
(after 14 days cure at 77°F and 50% RH)**

Property	Value
Hardness (Shore A)	40 - 45
Modulus @ 100% Elongation	65 psi
Tensile Strength	240 psi
Elongation	850%
Adhesion in Peel	>25 piw
Stain and Color Change	None
Ozone Resistance	Excellent
Joint Movement Capability	±25%
UV Resistance	Good
Heat and Aging	Good
Temperature Resistance	-40° to 180°F

**Values given above are not intended to be used in*

Installation Materials Required

1. Welder (MIG preferred)
2. Welding safety equipment
3. Safety glasses and work gloves
4. Face mask or respirator
5. Pipe segments (1 $\frac{3}{4}$ " O.D. x 2" long) - quantity 10
6. High volume fans – quantity 2
7. ABC fire extinguisher
8. 5 gallon pail of water
9. Clean cloth rags – 1 bundle
10. $\frac{1}{2}$ " variable speed drill with bit assortment
11. Reciprocating saw with blade assortment
12. Shop-vac
13. Pliers
14. Screwdriver
15. Trowels, 4" square end preferred
16. 5 lb. hammer
17. Pry bar
18. Clamps
19. Tape measure
20. Chalk line
21. Spray bottle (water)
22. Plywood boards* (1/4" x 24" x 24") – quantity 2

*Optional: Knee pads for slag protection

Estimated time for Liner Installation: Approximately 55 man hours
(5 hours layout, 25 hours welding, 20 hours lining and installing blades, 5 hours seam preparation)



Always perform installation procedure in an open, well-ventilated area.

INSTALLATION

Figure 1

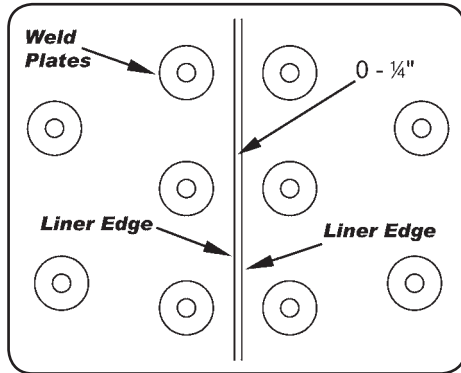

Proper Spacing

Due to drum fabrication tolerances and to ensure the best fit and even liner spacing, some forethought is required. Most liner segments come in eight preformed panels per drum section. It is important to evenly space these liner panels to ensure minimal gaps. Ideal spacing between liner panels is $\frac{1}{4}$ " or less (figure 1). This spacing may vary with older drums or drums that have been warped or altered. Ideal installation temperature is 65°F to minimize thermal expansion or contraction.

It is important to get the liner panels square to the drum. Many mixer manufacturers have a weld seam that can be used as a guide. If this is not available, use a chalk line to mark a straight line on the inside of the drum that spans from the charge opening to the discharge opening.

Use the weld seam or chalk line as an alignment reference to position two liner panels of each drum section together. Start with the belly section, then the charge cone section, discharge cone section and the back wall. If the drum has a removable cone it will be lined later.

Lay a $\frac{1}{2}$ " bead of Bostik 1100FS adhesive (Bostik 1100FS is specified by Argonics. See page 3 for more information) along the edge of the weld seam or the chalk line. Flatten with a putty knife and position the edge of the first liner against the weld seam or chalk line making certain that it is square. Next check to make sure that the liner is laying flat against the drum substrate then tack weld the weld holes along the perimeter as well as a few of the center holes of the liner panel.

BE CERTAIN THAT THE TACK WELDS ARE SUFFICIENT TO HOLD THE WEIGHT OF THE LINER PANEL BEFORE ROTATING THE DRUM.

Before positioning the second liner section, lay another $\frac{1}{2}$ " wide bead of Bostik 1100FS along the edge of the first section where the next liner section will be installed. Move the second liner section into place making sure that the liner is laying flat against the drum substrate. Tack weld the weld holes along the perimeter as well as a few of the center holes of the liner panel. Use a putty knife to remove any excess Bostik from the seam.

Important:

Once two liner panels from each section are positioned, measure the arc of each drum section that remains unlined. The unlined area should be equal to 75% of the total circumference (figure 2). If the balance is greater than 75%, you will need to gap the remaining liner panels. If the balance is less than 75%, you will need to trim the remaining liner panels. To determine the anticipated gap or trim requirement, divide the difference into the number of seams ($\frac{1}{8}$ " difference equals $7 - \frac{1}{8}$ " gaps). Continue positioning, caulking and tacking liner panels. Repeat the above procedure after each panel has been placed.

Figure 3

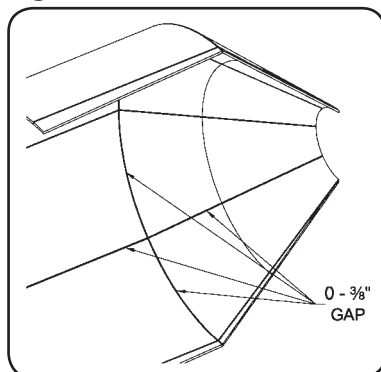
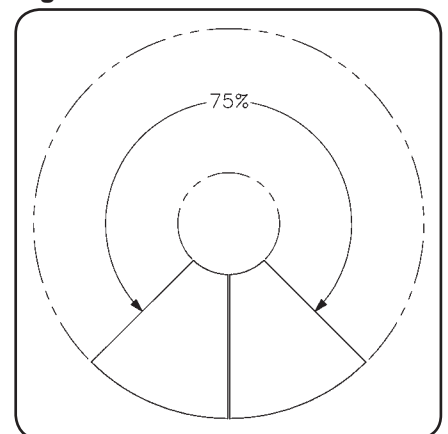
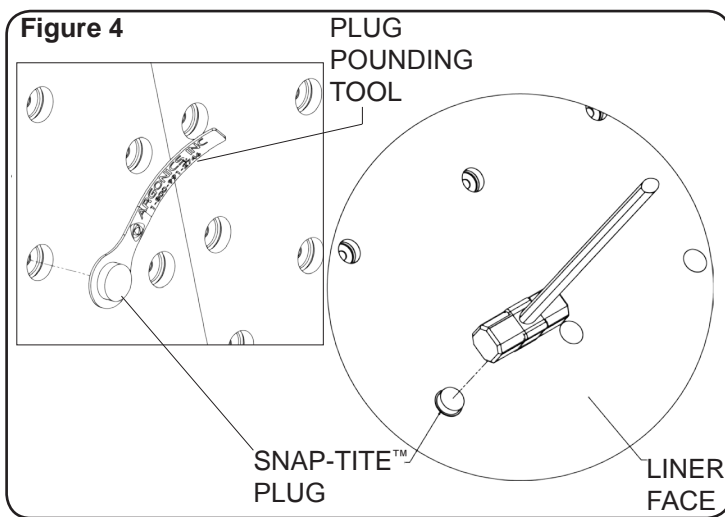

Figure 2



All gaps (if any) should be equal. If a gap larger than $\frac{3}{8}$ " exists, the liner panels should be repositioned until the gaps are equalized (figure 3).



Snap-Tite™ Plugs Installation

Snap-Tite plugs are designed to have a very tight fit. They are made this way to prevent the plug from popping out. One effective way of installing plugs is the sledge hammer method. Place the plug over the weld hole and hit it with the top flat portion of the hammer head (figure 4).

The Snap-Tite Plug Pounding Tool can be used to hold the plugs in place while installing on a vertical wall liner where the plug will not rest in place on the liner. The handle of the tool may be bent to more comfortably fit the contours of your hand.

Removable Cones

Secure the unlined cone to the drum shell. Trace the diameter of the discharge cone opening onto the inner surface of the removable cone. Remove the cone from the drum. The traced line should be two or three inches inward from the large diameter of the cone (figure 5). This line will serve as a guide for the large arc edge of the liners. Slide the liners along the cone slope until flush with the traced line. Mark clock positions and install as before (equalizing gaps, trimming excess).

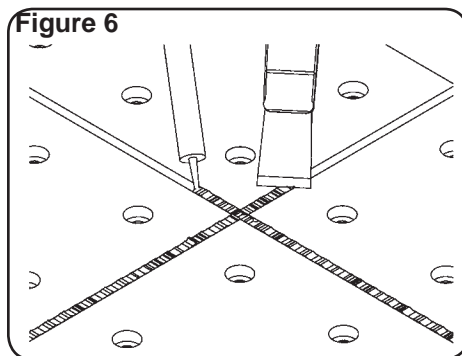
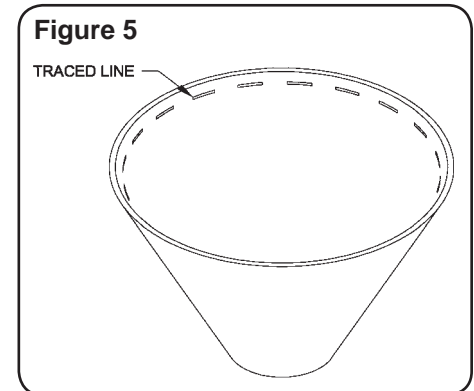

Sealing Gaps

After all liners are in place, caulk any remaining gaps with Bostik 1100FS adhesive (figure 6). To do so, lay a bead of Bostik in seam and flatten out with a putty knife pushing Bostik into seam. Use the putty knife to remove any excess Bostik from around the seam area making sure the Bostik is flush with the liners.

Lining the Blades

Position the liners onto the appropriate areas of the blades. If there is confusion as to which blade liner section goes where, contact your Argonics representative for an orientation print. Once you are sure of placement, remove the liners and apply a generous bead of Bostik 1100FS adhesive around the perimeter of the area to be lined. While the caulk is still soft, reposition the liner segments then clamp and weld into place. The caulk should seep out from the edge of the liner. It is further recommended to weld 3/8" round or square bar stock on all leading edges. This extra step helps minimize forced penetration at the edge (figure 7).

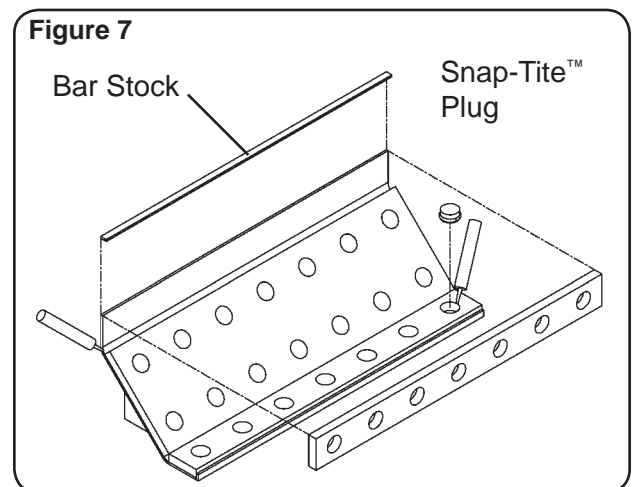

Installing the Blades Once the drum liners are in place, locate the blade pedestal bolt holes on the outside of the drum. Using these holes as a guide, drill 7/8" holes through the liners from the outside in. Return to the inside of the drum and bore out these same holes to the steel drum using a 1 1/4" diameter standard bit (or contact Argonics for an optional counterbore tool). Place the OEM-supplied bolt bushings into these holes. If these are not available, you may substitute 1" black pipe with a 1 1/4" O.D. Cut the black pipe into segments of 15/16" high. Refasten the blade weldments as prescribed by the OEM.

REMOVAL PROCEDURE

Removal Materials Required

1. Oxy-acetylene hand torch or air arc
2. Welding safety equipment
3. Portable or overhead crane
4. Blocking material
5. Safety glasses and work gloves
4. Face mask or respirator
5. ABC fire extinguisher
6. Compressed air or shop-vac
7. High torque, low speed drill with a 200 or 250 RPM setting
8. 1¾" diameter standard hole saw (not carbide tip) –45/60 pcs.
9. Number 2 arbor for hole saw
10. Tapered chuck
11. Portable grinder with 9" grinding disk
12. 5 lb. hammer
13. Pry bar
14. Chisel

Estimated time for liner removal: Approximately 45 man hours
(5 hours blade removal, 25 hours drilling steel inserts, 15 hours prying, chiseling and grinding)



Do not burn the waste. The decomposition of polyurethane during melting or ignition will generate toxic and irritating fumes.

Always perform removal procedure in an open, well-ventilated area. Remove one blade structure at a time. Securely block up each blade structure in order to prevent it from falling when the bolts are removed. Remove the bolts by burning off the bolt heads on the outside of the drum. Carefully remove all blade structures using a portable or overhead crane. Try to salvage bolt spacer bushings for reinstallation.

Remove the weld hole plugs by prying them out with a large screwdriver or pry bar. Set the drill to 200 or 250 rpm. Using a hole saw, cut through each 1/8" thick weld disk that secures the liner panel to the drum shell. Be careful not to score the drum shell.

Pry up the liner panels at each plug hole to ensure that the steel disk has been completely cut through. Remove each panel as necessary. Use a hammer and chisel to remove any seam adhesive stuck to the drum. Grind off the remaining weld disks flush with the drum. Remove the polyurethane blade liners by following the same procedure.

Use the vacuum to clean the surface and contain dust particles as you proceed. Dispose of the vacuum cleaner bag or contents and the liner waste in accordance with federal, state and local regulations.

PROPER CARE AND MAINTENANCE

The purchase of this liner is a substantial investment. Maximum cost effective performance can be reached though proper care and maintenance.

The following tips should be observed:

Storage - If the mixer will be out of service for long periods of time, protect it from the elements. Solar heat can cause thermal decomposition and stagnant water may promote absorption, both of which can degrade the liner over time. Cover openings and tilt the mixer for proper drainage.

Loose Plugs - Plugs should fit snug. If a plug becomes loose or pops out, it may allow material penetration or buildup through the weld hole. Try to remove the buildup, and use Bostik 1100FS adhesive to seal the hole or secure the loose plugs as soon as possible. If you experience this problem at any point in the life cycle, you may request additional plugs from the factory. They will be supplied at no charge.

Cleaning - The objective is to loosen and remove any concrete buildup that may occur during normal production. A high-pressure hose should be used to remove stubborn deposits before they have a chance to harden and grow. Run cycles of water through the mixer at the end of each production period or before the mixer will sit idle. A daily rinse is recommended, and more often when dealing with fast setting admixes. Cycles of clean, ¾" fractured aggregate may also be used in conjunction with the water, if build up is wide spread (like when using Cement Treated Base).

Chipping – When chipping is required, be sure to use a respirator to protect from silica exposure. When possible, use plywood boards to protect liners from miscues that could result in gouges or tears. For areas around the blades, air chisels are more maneuverable and less bulky. For build up on seams or on other drum sections, use wide displacement strikes. The resilient urethane should compress enough to release the concrete without chiseling.

Gouges or Tears - If a gouge or tear occurs, Bostik 1100FS adhesive can be used to fill holes or affix patches to damaged areas. The affected area should be cleaned, dried, stripped of grease or other contaminants, and patched. This should be done as soon as possible to eliminate aggravation or dispersal.

Seam Care - Seams are generally the most susceptible areas. If material penetration starts to cause problems along a liner seam, damage can quickly spread. Seams should be inspected weekly and re-sealed or repaired as required.

Visual Inspection - Checking a drum liner on a regular basis is very important in preventing material impediment. Failure to do so can result in premature liner loss. Argonics recommends that all mixer liners be inspected on a **weekly basis** for thin spots, broken or loose welds, missing Bostik in seams and loose or missing Snap-Loc plugs. If any of these conditions arise it should be taken care of immediately.

Worn Blades - Blade liners typically wear out much faster than the drum liners, often exhibiting a 1-to-2.5 wear ratio. This is due to the shearing action of the mix environment. Argonics recommends welding bar stock along the leading edges of the blade liners to resist material penetration between the poly liner and the steel blade.

Blade Tips - Most blade liner kits are designed with replaceable tip sections at the perimeter. These areas are the most susceptible and often are the first areas to require replacement. If replacement is postponed, the steel blades themselves may be damaged. This could mean replacing the entire blade weldment. Be sure to replace blade tips as necessary.



NOTES



NOTES



**Largest Selection of
Conveyor Belt Cleaner
Replacement Blades**



*The World's Best Conveyor
Belt Cleaning Systems*

Eraser™
Conveyor Cleaners

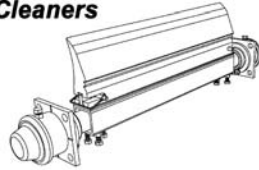

**The Most Complete Line
of Conveyor Support Systems**



Impact - Slide - Roll & Slide

Also Available From:



**Classifier Shoes
Screen Deck Accessories
Belt Skirting
Snap-Loc Dust Seal
Modular Wear Liners
Wear Resistant Sheets
Concrete Mixer Lining Systems**